



TECHNICAL DATA

BLOW MOULDER TYPE	BBM	4-100E	6-100EL	8-100E	10-100E
Clamping force	[kN]	180	240	300	400
CLAMPING UNITS					
Mould length (A) max.	[mm]	465	465	490	620
Mould width (B) max.	[mm]	550	750	900	1050
Mould depth (C)	[mm]	2x180	2x180	2x180	2x180
Opening stroke (D)	[mm]	320	320	320	320
PRODUCTION POSSIBILITIES					
2-fold (volume)	[Litre]	5	10	-	-
3-fold, centre distance	[mm]	170	240	280	340
4-fold, centre distance	[mm]	125	170	210	250
6-fold, centre distance	[mm]	-	115	140	170
8-fold, centre distance	[mm]	-	85	100	125
12-fold, centre distance	[mm]	-	-	70	85
EXTRUDERS					
RHF	[L/D]	50/30	60/33	70/33	90/33
Output HDPE (max.)	[kg/h]	110	200	300	400
DIMENSIONS AND WEIGHTS					
Length	[mm]	5500	5700	5900	6000
Width	[mm]	3200	4300	4900	5400
Height	[mm]	3800	3800	4000	4200
Weight	[to]	15	23	25	27

All data is for information and guidance purposes only. Errors and omissions excepted.

MAIN FEATURES

- Electric single station extrusion blow moulding machine for consumer packaging
- Clamping unit with article to the front, right, left or back
- 30 – 50 % energy saving compared to hydraulic machines
- Low maintenance costs (no oil, filters, leakages)
- Low noise level and precise – right from the first cycle
- Easy access to the production and maintenance area with wide opening safety gates
- Mould thickness and clamping force adjustment, directly at the operator panel
- RHF high output extruders with a high L/D-ratio for all common polyolefines
- Extruders allow screw removal to the back
- Coated extrusion heads for best surrounding distribution and easy colour changes
- BBM „BlowControl 2“ with Multi-Touch Screen
- Proportional control for profiled blow and support air
- Remote control for tele-service via Internet
- Optional: multi-layer, post-cooling stations, IML, view stripe, quick-change devices

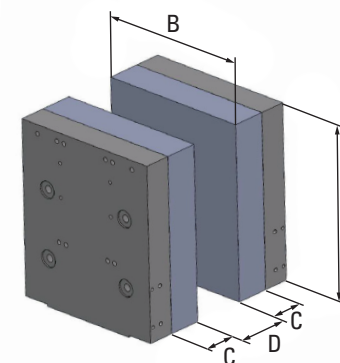

BBM 4-100E / 6-100EL
BBM 8-100E / 10-100E

BBM Maschinenbau und Vertriebs GmbH

Dieselstr. 3 - 5
D-33449 Langenberg
Germany

Tel.: +49 (0) 52 48 82 38 - 0
Fax: +49 (0) 52 48 82 38 - 295

E-Mail: sales@bbm-germany.de
Web: www.bbm-germany.de

10/2016